

## NSI-800F-10

### Far-field Antenna Measurement System



#### DESCRIPTION

The NSI model 800F-10 Far-field Antenna Measurement System is a cost-effective, easy-to-use system for taking principal plane, far-field antenna measurements. This system is compact and lightweight. It is ideal for universities or small commercial companies that want to test small, lightweight, and low gain antennas.

#### SYSTEM CAPABILITIES

The 800F-10 system supplies everything you need to begin testing of antennas with customer supplied RF equipment and source horn (Note, NSI can also supply these items if so desired). The system can interface to a variety of RF equipment, such as the Agilent PNA, Agilent ENA, to the NSI high performance RF equipment and more (contact NSI sales department for more information). The 800F-10 system consists of the following components:

- NSI's industry-leading Far-field antenna measurement software and workstation
- High precision azimuth rotation stage
- Control electronics & cabling
- RF cables
- User documentation
- Two year warranty

Lastly, the 800F-10 system can be easily upgraded to the NSI-800F-20 with additional axes for complete 3D characterization of the antenna under test. And with the addition of the NSI 2000 Near-field Software the user can perform spherical near-field measurements.

SPECIFICATIONS	
Frequency Range	Full frequency range supported by RF Equipment
Drive System	Precision Stepper Motor
Maximum Antenna Load (Typical)	55 lb (25 kg)
Position Resolution	0.01°
Position Repeatability	0.03°
Rotation Speed	40°/s
Measurement System	Measurement workstation computer with
Motor Cable	Quick-connect; 40' (12.2m)
RF Cables	20' (6.1m); DC-18 GHz; with SMA connectors (Qty:2)
Rotary Joint	DC - 26.5 GHz
Supported RF Devices	Selection of Agilent, Rohde & Schwarz and Anritsu VNA's (contact NSI for a complete list)
AC Power	100-240 VAC switchable, 50/60 Hz
Environmental	Indoor Rated

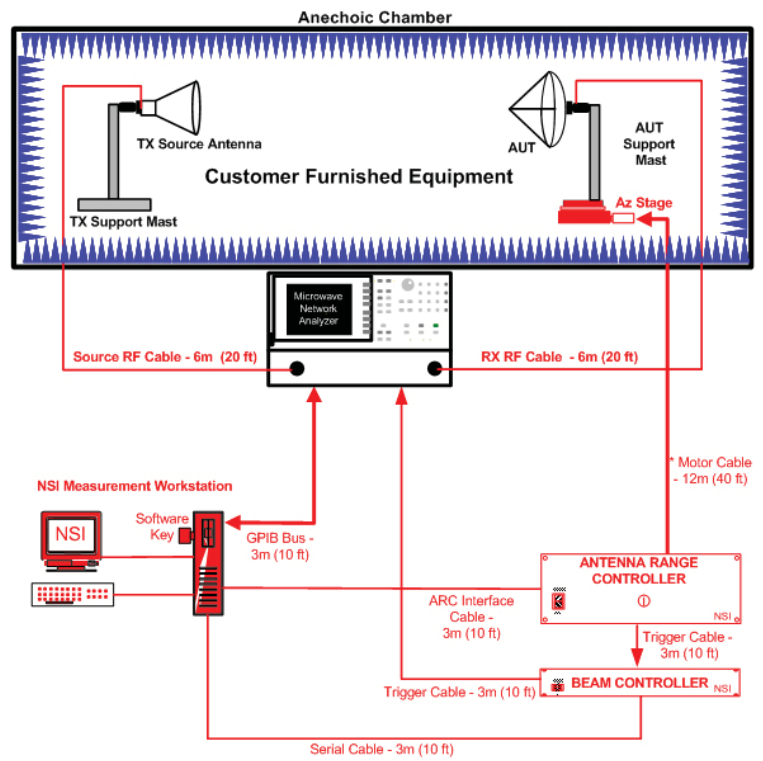

**NSI-800F-10 Measurement System**

## SYSTEM OPTIONS

- Opt 100 - 220 V AC, 50 Hz operation.
- Opt 106 - Upgrade standard azimuth stage to high capacity NSI-SC-5635 stage.
- NSI-SC-5606 - 2nd Axis & Antenna mounting kit. Motorized roll stage - 4' height - 40' motor cable, base unit, and hardware includes an upgrade to a multi axis motor controller.
- NSI-SC-5650 - Transmit antenna mounting stand - floor stand base and adjustable mounting bracket for mounting antennas up to 50 lbs. Includes base with adjustable feet, 4' vertical rail, slide plate for mounting of antennas.
- NSI-RF-SGXX - Full complement of standard Gain Horns

## Nearfield Systems, Incorporated

19730 Magellan Drive, Torrance, CA 90502, USA, Tel: 310.525.7000, Fax: 310.525.7100  
 Email: sales@nearfield.com. Visit our website: www.nearfield.com